

With Us, You can

HIGH GREEN SAFE

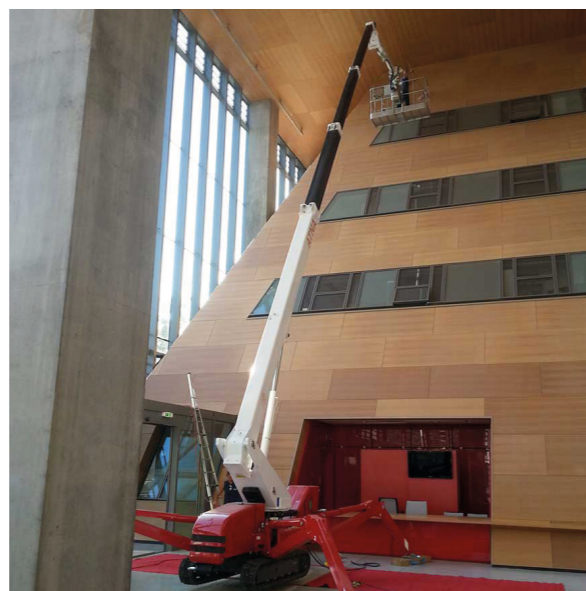

22,3 m

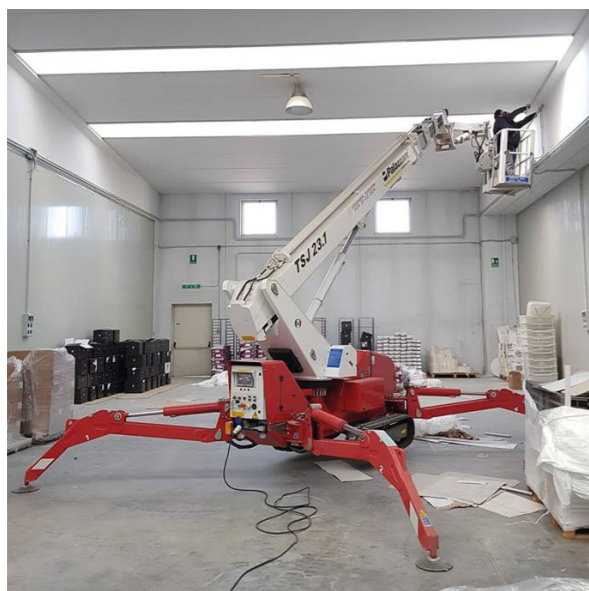

10,2 m



250 kg



Bi-energy
Eco



Crawlers
Wheels



SPIDER LIFT

OPTIONAL



STANDARD EQUIPMENT

- Available power options: Bi-energy (Diesel + AC), Eco (AC+Battery)
- Hydraulic steering and transmission on rubber tracks with hydraulically variable external width
- Independent Outriggers rotating on 2 different positions
- Automatic set-up with self-levelling
- Turntable rotation at 660°
- CANBUS electronics
- Steel made telescopic boom
- Hydraulic and electric lines inside the boom
- Removable aluminium alloy aerial cage 150x70x110 cm, with hydraulic rotation 90° + 80°
- "Area manager" limiting device for safe working load 250 kg
- Load sensor on the cage
- Cable control for cage/ground
- 230VAC electric plug on the cage
- PalSystem with touchscreen monitor for diagnostics and monitoring of operating parameters
- Standard colors: chassis and stabilizers red RAL 3000 - turret and boom white RAL 9003
- CE Mark homologation certificates, manuals, stickers and spares book in English language



HYDRAULIC WINCH 500 KG

The winch, replacing the basket, allows to transform the Spider lift in Spider crane with a maximum lifting capacity of 500 kg. It is supplied with a special mobile support for the basket disassembled.

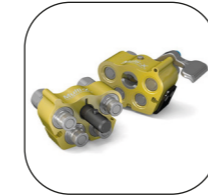

QUICK PIPES COUPLING KIT FOR HYDRAULIC WINCH 500 KG

Coupling system and quick release of the hydraulic winch to accelerate and speed up the replacement between basket and winch, reducing significantly the machine downtime.



PROTECTION OF PRUNERS

Covers kit in iron for delicate parts of the machine such as cylinders stems, valves and reels to protect against branches or other materials falling from above.

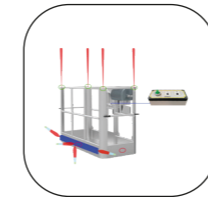

BASKET ANTI-COLLISION KIT

The laser sensors are positioned at the four corners of the basket and monitor the distance between the operator and any vertical obstacles. Ultrasonic sensors check the presence of any obstacles around the perimeter.



NON-MARKING TRACKS

white rubber, ideal to operate indoor and/ or on delicate floors



PEDAL TO THE CAGE

Safety pedal to operate the movements from the cage.



ADDITIONAL AIR/WATER PIPES

Extra-large diameter compressed air/water pipe to the basket.

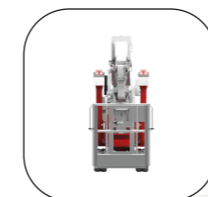

CAGE 70x70x110

One-man aluminum cage size 70x70 cm, suitable for work in particularly narrow spaces.



KIT PALCONNECT

Remote connection service with the aerial platform that allows the user to monitor the key parameters of use of the machine and intervene with some of them.

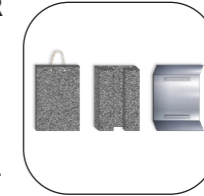

PADS FOR OUTRIGGERS

Different type of pads to distribute the load of the stabilizers on the ground and have greater stability of the machine.



CUSTOMIZED COLOURS

Possibility to customize the colours of the tracked lift with different RAL according to the client's corporate livery



LED LIGHT

One or more additional led headlights installed on the basket or on the boom.



RADIO CONTROL

Circuit of radio-wave driven controls, for ground operation even at a great distance.

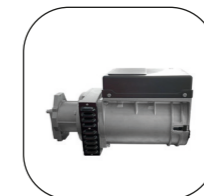

ELECTRIC GENERATOR

230VCA single-phase, powered by the diesel engine, connected to an electrical socket in the cage, for the use of electrical tools during aerial working



INTERCOM CIRCUIT

electronic device for voice communication between the operator at height in the basket and the operator on the ground



ANEMOMETER

device for measuring the wind, with an acoustic warning of the wind max speed allowed for aerial working



BI-ENERGY

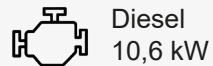

Diesel
10,6 kW



Single-phase
Electric motor
230VAC - 2,2 kW

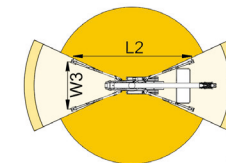
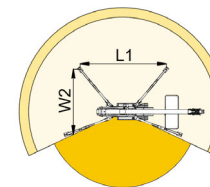
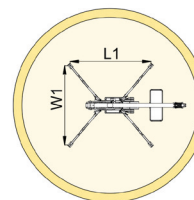
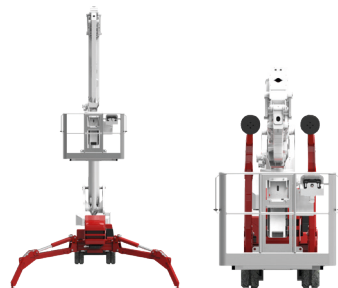
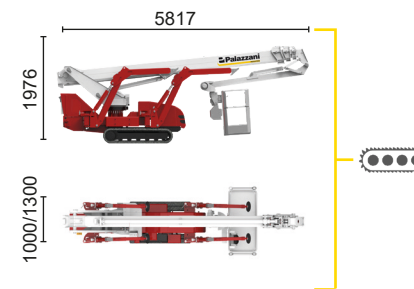
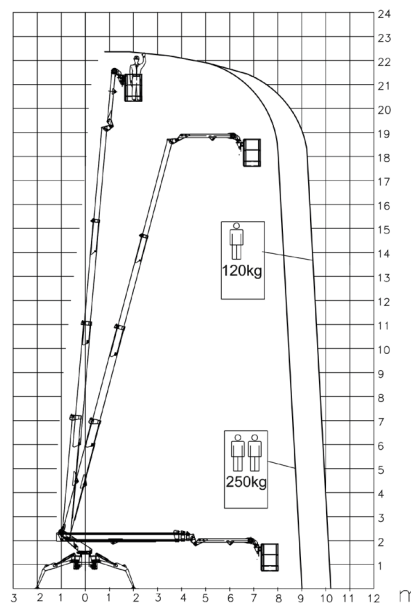

9 m	10,2 m	6 m	L1	L2	W1	W2	W3
250 kg	120 kg	250/120 kg	4900 mm	6250 mm	4350 mm	3350 mm	2750 mm



TSJ 23.1/C  22,3 m 10,2 m 250 kg 660° 150x70 cm 90°+80° 2,75-4,35 m 36% 29% 2,4 km/h 3370 kg 19 kN 1,58 kN/m² 3,86 kN/m²

Available power options:

BI-ENERGY (DIESEL+AC)

ECO (AC+BATTERY)

Characteristics and technical data are informative only and subjected to change without notice.

Palazzani Industrie S.p.A.

Via del Pavione, 4 - 25050 - Paderno F.C. (BS) - Italy

Tel. (+39) 0306857073

info@palazzani.it

www.palazzani.it



NC 803 A 22



BI-ENERGY



Diesel
10,6 kW



Single-phase
Electric motor
230VAC - 2,2 kW

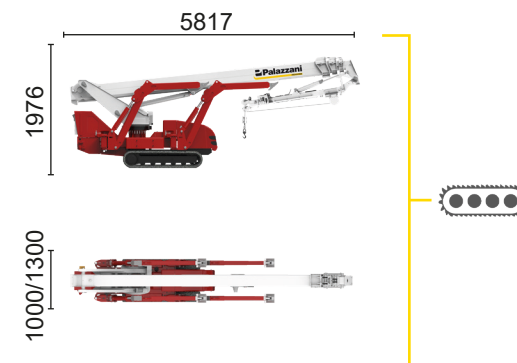
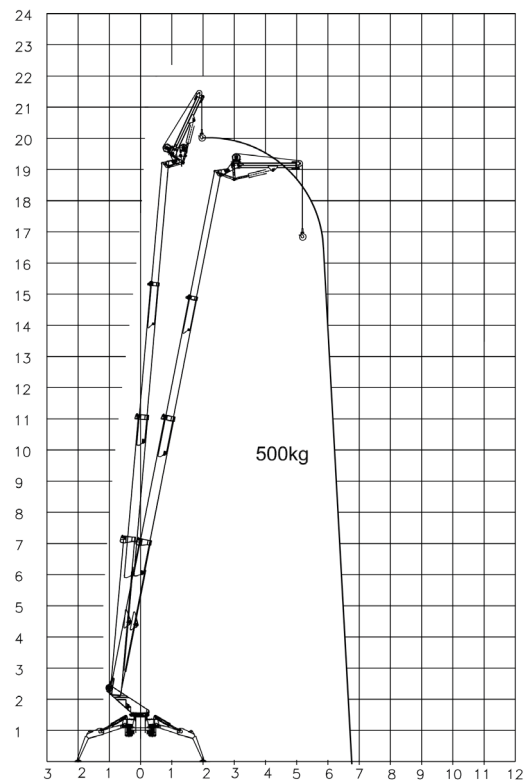

TSJ 23.1/C  21,5 m 7 m 500 kg 660° 150x70 cm 90°+80° 2,75-4,35 m 36% 29% 2,4 km/h 3370 kg 19 kN 1,58 kN/m² 3,86 kN/m²

Available power options:

BI-ENERGY (DIESEL+AC)

ECO (AC+BATTERY)

Characteristics and technical data are informative only and subjected to change without notice.

Palazzani Industrie S.p.A.

Via del Pavione, 4 - 25050 - Paderno F.C. (BS) - Italy

Tel. (+39) 0306857073

info@palazzani.it

www.palazzani.it



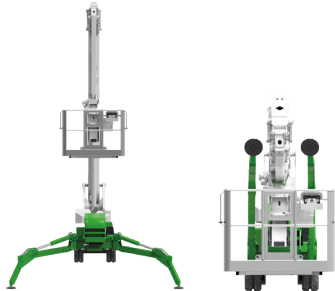

ECO

 Single-phase
Electric motor

 Lithium iron
phosphate battery
LiFePO4
48V 360Ah

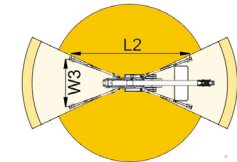
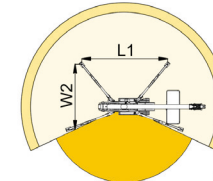
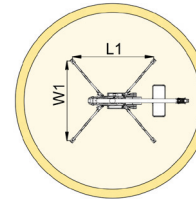
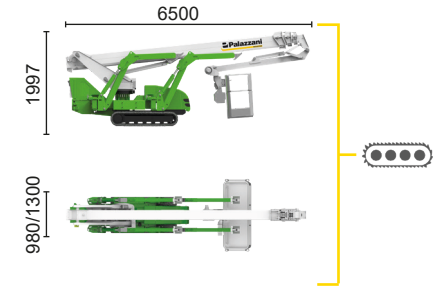
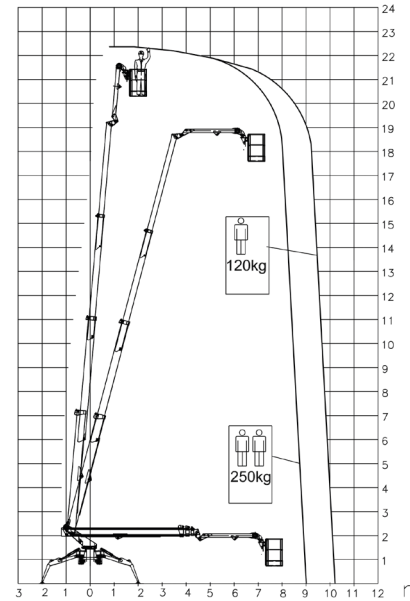

9 m	10,2 m	6 m	L1	L2	W1	W2	W3
250 kg	120 kg	250/120 kg	4900 mm	6250 mm	4350 mm	3350 mm	2750 mm

TSJ 23.1/C  22,3 m 10,2 m 250 kg 660° 150x70 cm 90°+80° 2,75-4,35 m 36% 29% 1,5 km/h 3370 kg 19 kN 1,58 kN/m² 3,86 kN/m²

Available power options:

 **BI-ENERGY** (DIESEL+AC)

 **ECO** (AC+BATTERY)

Characteristics and technical data are informative only and subjected to change without notice.

Palazzani Industrie S.p.A.

Via del Pavione, 4 - 25050 - Paderno F.C. (BS) - Italy

Tel. (+39) 0306857073

info@palazzani.it

www.palazzani.it











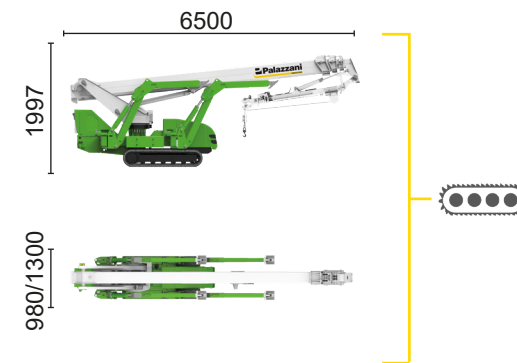
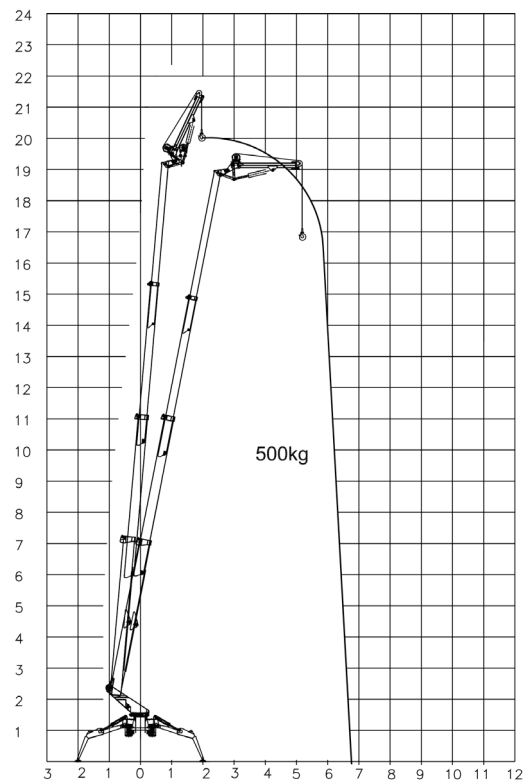









ECO

 Single-phase
Electric motor

 Lithium iron
phosphate battery
LiFePO4
48V 360Ah



TZX 23.1/C		 21,5 m	 7 m	 500 kg	 660°	 150x70 cm	 90°+80°	 2,75-4,35 m	 36%	 29%	 1,5 km/h	 3370 kg	 19 kN	 1,58 kN/m ²	 3,86 kN/m ²
------------	---	--	---	--	--	---	--	---	---	---	--	---	---	--	--

Available power options:

BI-ENERGY (DIESEL+AC)

ECO (AC+BATTERY)

Characteristics and technical data are informative only and subjected to change without notice.

Palazzani Industrie S.p.A.

Via del Pavione, 4 - 25050 - Paderno F.C. (BS) - Italy

Tel. (+39) 0306857073

info@palazzani.it

www.palazzani.it

